



MiniServo® 1.5 Servo motor allrounder

- Very short removal time by means of increased acceleration and speed
- For removal of sprues and parts weighing up to 1.5 kg
- For injection moulding machines of up to 3000 kN

Axis	Description	Stroke (mm)	V max. (m/s)
X	Removal stroke	0 - 300	0,3
Y/Z	Vertical stroke/ Transversal stroke	0 - 800 (600, 1000)	2,0
A	Swivel axis	$\pm 110^\circ$	200°/sec

Technical standard specifications

- All the axes with DC servomotors
- Repeating accuracy: X- and Y-axes $\pm 0,1\text{mm}$ / A-axis $\pm 0,1^\circ$
- Part and gripper weight together: up to 1,5 kg
- Mains supply: 230/115 V (50/60 Hz)
- Power rating: 250 VA
- Compressed air supply: 6 bar, consumption approx. 0,3 NI/cycle (without vacuum)
- Gripper F
- One compressed air and one vacuum circuit
- Rotation module B with adjustable limit stops
- Sliding console
- Freely programmable control MiniControl including EasyTeach
- All the standard Euromap 67 signals

Measured cycle

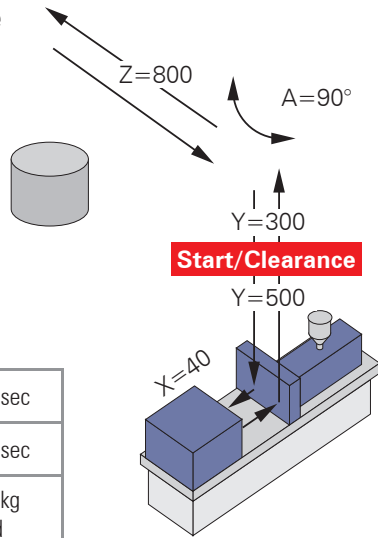

Time of action:	1,2 sec
Total cycle-time:	5,1 sec
Dry running period with:	1,5 kg load

Options

- Gripper monitoring feature, maximum 2 units
- Monitoring B-module
- 1 additional compressed air and vacuum circuit
- Blow-off function for the compact ejectors
- Gripper K and additional special grippers
- PC programming software (offline) EasySoft
- Disk drive unit for data safeguarding
- A linkage of the hardware by means of RS485
- CAN islands to control the peripheral devices
- Adapter for Euromap 12 signals
- Rotation console 2x90° indexed
- Further options upon request

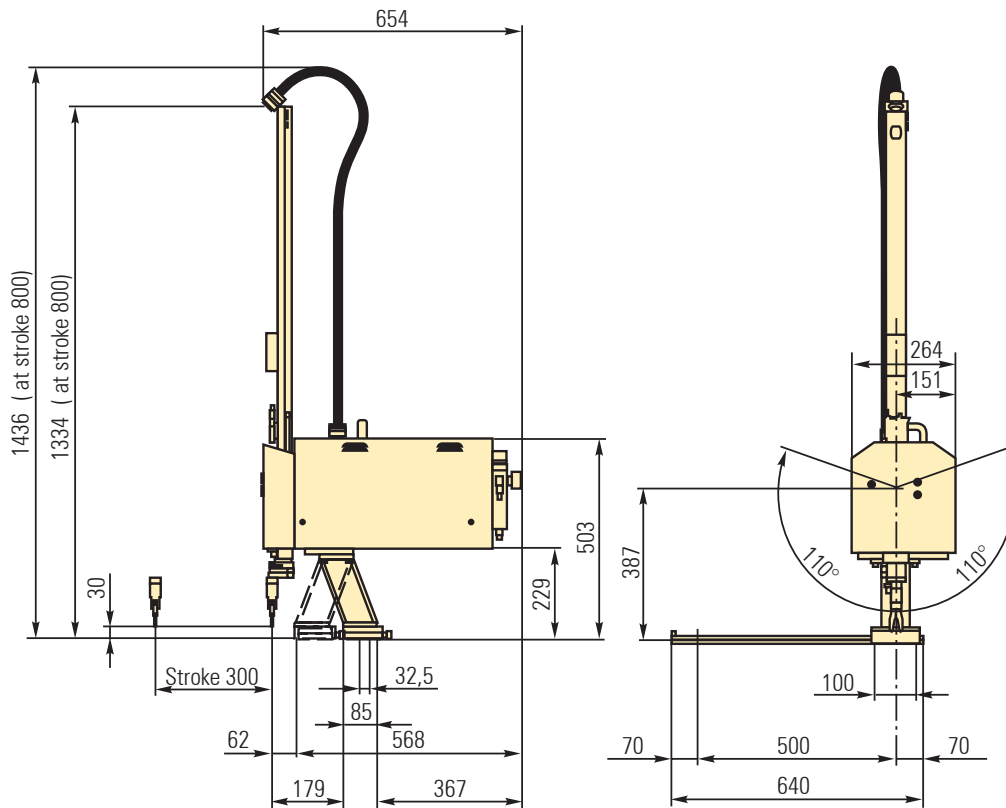

All data subject to change. Specifications and images for information purposes only.