

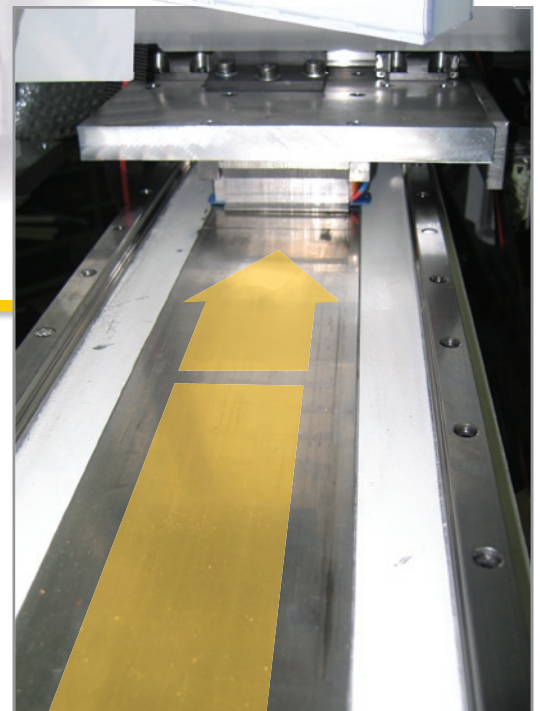

LR 200 Linear robot

- For challenging handling and automation tasks
- For injection moulding machines of up to 25000 kN
- Economic and fast by means of a high-dynamic linear drive system (optional)



Axis	Description	Stroke (mm)	V max. (m/s)
X	Removal stroke	800 (600, 1000)	1,9
Y	Vertical stroke	1600 (1400, 2200)	2,6
Z	Transversal stroke	2400 (3000, 4000, 4400, 4500, 5000, 6000))	2,0 (4,0 optional)

Measured cycle

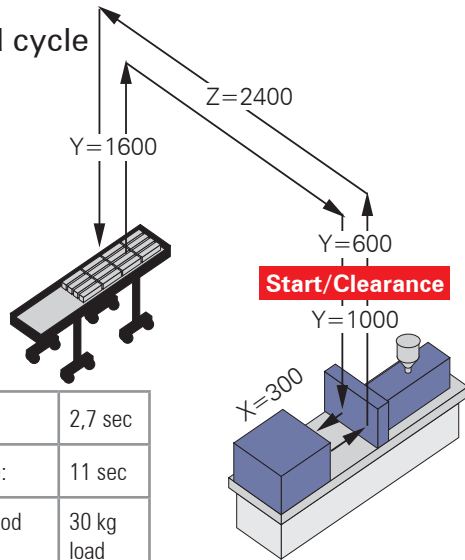

Time of action:	2,7 sec
Total cycle-time:	11 sec
Dry running period with:	30 kg load

Technical standard specifications

- X-, Y-, Z-axes with AC servo motors
- Repeating accuracy: $\pm 0,1$ mm
- Part and gripper weight together: up to 30 kg
- Mains voltage: 400-480 V (50/60 Hz)
- Power rating: 1000 VA
- Compressed air supply: 6 bar, consumption approx. 2 NI/cycle (without vacuum)
- Y-axis telescopic
- Two compressed air and two vacuum circuits
- Freely programmable control EasyControl including EasyTeach
- All the standard Euromap 67 signals

Options

- Additional compressed air and vacuum circuits
- Pneumatic A-, B- and C-rotation modules
- PC programming software (offline) EasySoft
- Linkage of the hardware by means of RS485
- CAN islands for controlling the peripheral devices
- SystemControl: Upgrade Kit for complex system engineering applications
- Adapter for Euromap 12 signals
- Further options upon request

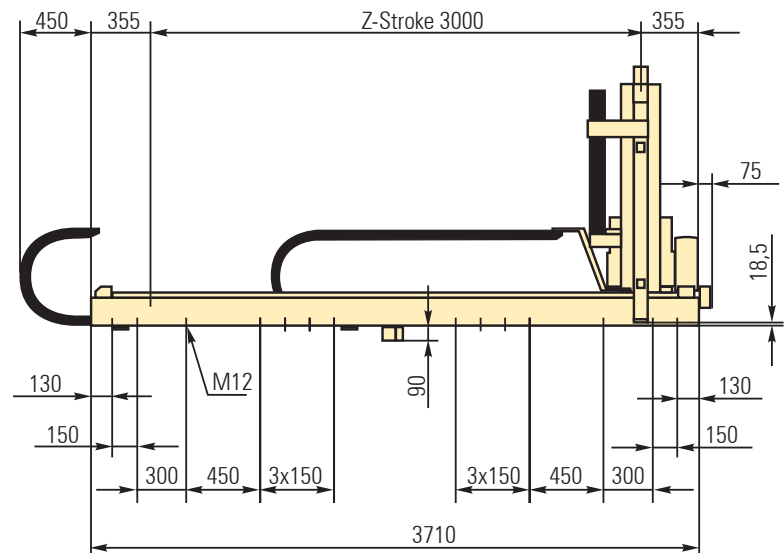
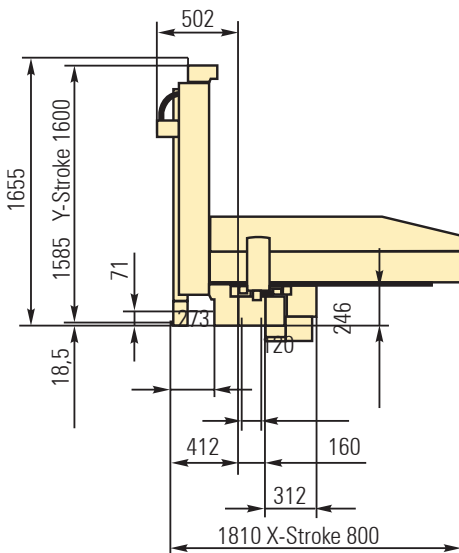

All data subject to change. Specifications and images for information purposes only.