



EA-Mini 2001 SLI

Allrounder with integrated performance package

- Very short removal time by means of increased acceleration and speed
- Part and gripper weight together: up to 2,0 kg
- For injection moulding machines up to 3000 KN

Axis	Description	Stroke (mm)
X	Removal stroke	0 - 190*
Y/Z	Vertical stroke/ Transversal stroke	400 - 700* (300 -500)*
A	Swivel axis	54-86**

*adjustable

Measured cycle

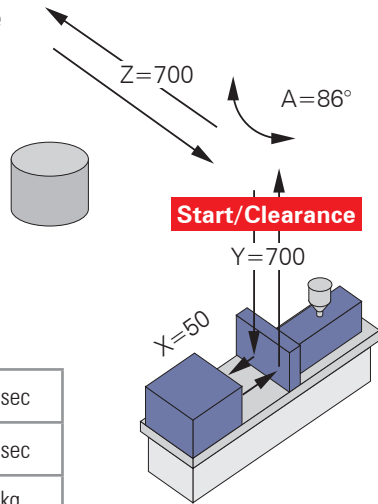

Time of action:	1,8 sec
Total cycle-time:	6,5 sec
Dry running period with:	2,0 kg load

Technical specifications

- All axes pneumatically driven
- Repeating accuracy: $\pm 0,2$ mm
- Part and gripper weight together: up to 2 kg
- Mains supply: 230/110 V (50/60Hz)
- Power rating: 60 VA
- Compressed air supply: 6 bar, air consumption about 10 NI/Zyklus (without vacuum)
- All Euromap 67 signals

Basic version

- Controller PMC 20
- Manual programming device PMC 20
- Rotating module B
- Vacuum circuit
- Metal gripper (gripper F)
- Sliding console
- unique high speed system on Y Axis

Options

- Rotatable console 2 x 90° indexed
- Special grippers
- End of arm tools
- Adapter for Euromap 12 signals

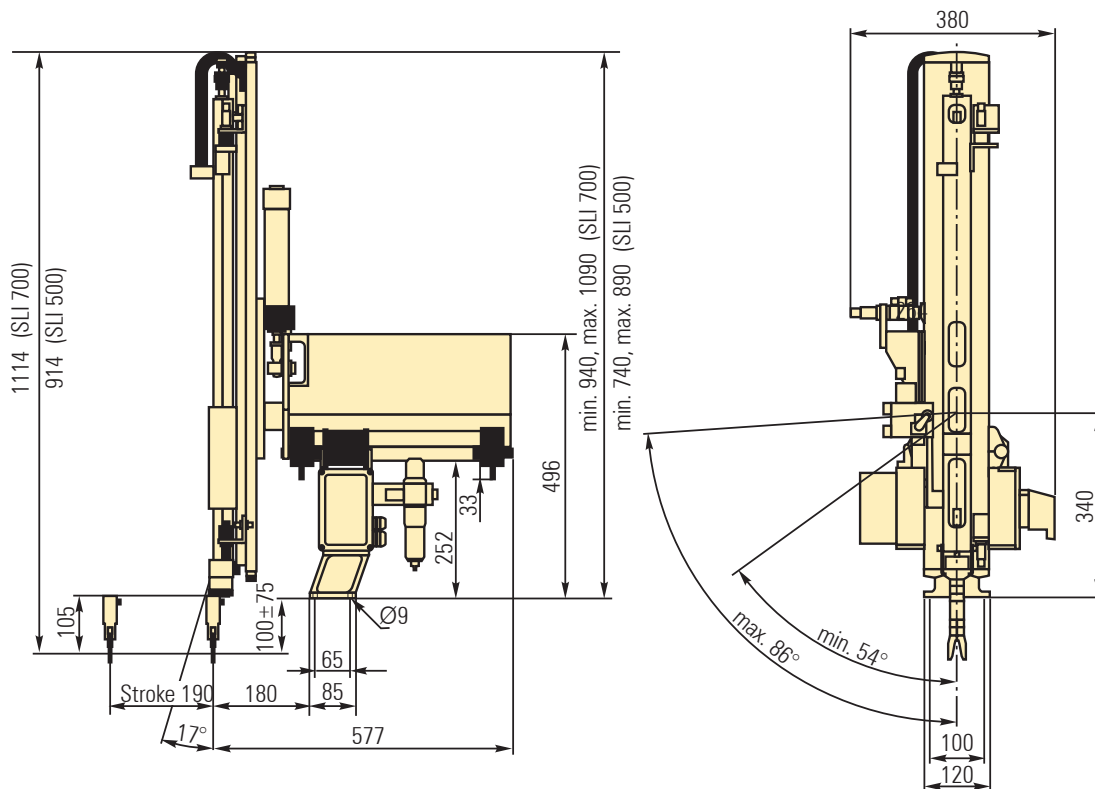

All data subject to change. Specifications and images for information purposes only.